



The **Model SVR SERIES** is designed to test Control Valves, Ball Valves in the vertical position with a hydraulic actuated clamping fixture.

Standard features include:

- 100-ton clamping fixture with Safety Interlock.
- 24" face to face valve clearance when fully retracted, 18 inch stroke cylinder.
- 3000 PSI hydrostatic shell test, optional 10,000 PSI system available.
- 100 PSI air test with panel mounted regulator
- Stainless steel seal plates with o-ring grooves to seal on flanges from 2" to 12" ANSI class 300
- Powder coated cabinet and frame for long lasting durability
- Safety Lexan® shield with frame with Safety Interlock to prevent testing unless shield is closed
- Safety Hydraulic Interlock valve prevents accidental release of clamping pressure when valves are under test pressure.
- Dual palm button clamping set up for added safety
- Optional push button controls available.

SVR-100

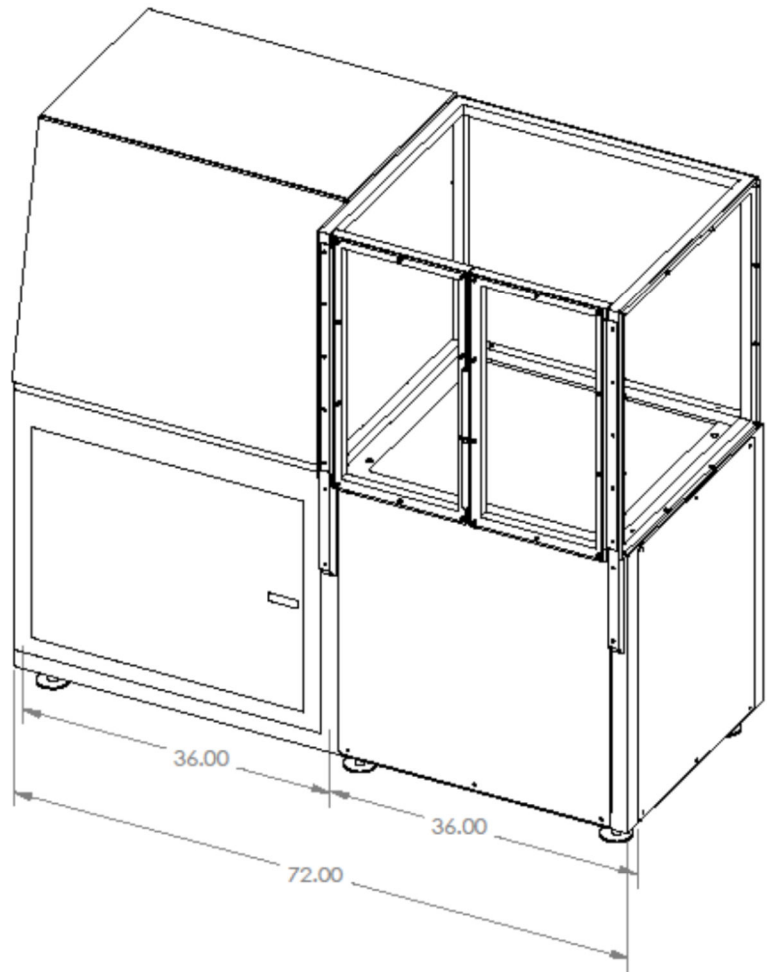
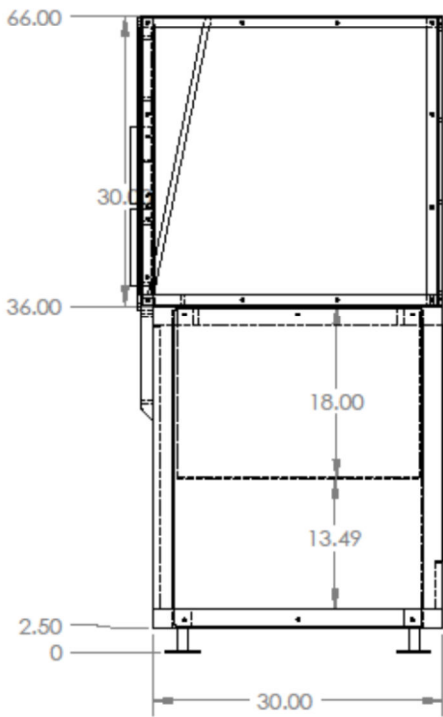

SVR-100 REAR VIEW

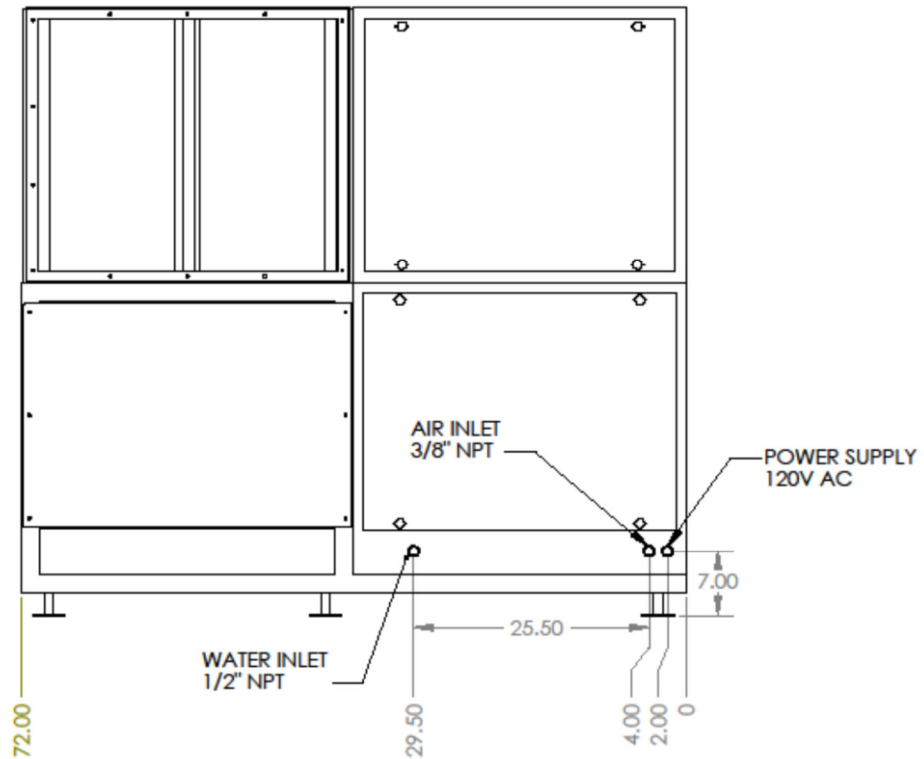



MODEL SVR SERIES VERTICAL VALVE TESTER

TEST COMPONENTS:

Flanged valves from 2" to 12" Class 300

TEST PRESSURE: 3000 PSI std. optional 10,000 PSI test system available. 100 PSI air tests.

CLAMPING FIXTURE:

100-ton hydraulic cylinder, 18 inch stroke. Seal plate has 1/2" NPT threaded outlet port with o-ring grooves to seal flanged valves . Maximum clearance of seal plates is 24" when fully retracted, 6" clearance when fully closed.

HYDRAULIC SYSTEM: 15 gallon capacity hydraulic power unit to move clamping cylinder quickly. Air driven piston pump for clamping pressures up to 10,000 PSI.

WATER RESERVOIR: Built in 20 gallon water reservoir with filtration system, centrifugal re-circulating pumps for continuous filtration. Optional water chiller and UV sterilizer set up available.

HYDROSTATIC SYSTEM:

PUMPS: Air-driven piston pump, 0-3000 PSI stand, optional 0-10,000 PSI hydrostatic test system.

GAUGES: 6" dial panel-mounted gauges, with chrome bezel, 0.5% accuracy full scale with Pressure Limiting Valves.

COMPONENTS: All high pressure valves, tubing and fittings stainless steel. All gauges, valves and regulators are panel mounted.

SAFETY FEATURES:

A Hydraulic Safety Interlock valve is installed in the circuit to prevent the accidental release of clamping pressure unless the test pressure is vented.

DATA ACQUISITION SYSTEM: (optional)

Digital gauge, PC, monitor, and printer, keyboard, mouse. Software and hardware with cables.

WARRANTY:

1 Year Full Warranty. (Refer to Barbee Terms and Conditions of Sale.)

VALVE TEST CAPABILITY						
ANSI CLASS	150	300	600	900	1500	2500
2" -10"	YES	YES	YES	NO	NO	NO
12"	YES	YES	NO	NO	NO	NO

DIMENSIONS: 72" L X 30" W X 84" H APPROX. 3500 LBS..